

URBAN BAR INSTALLATION GUIDELINES

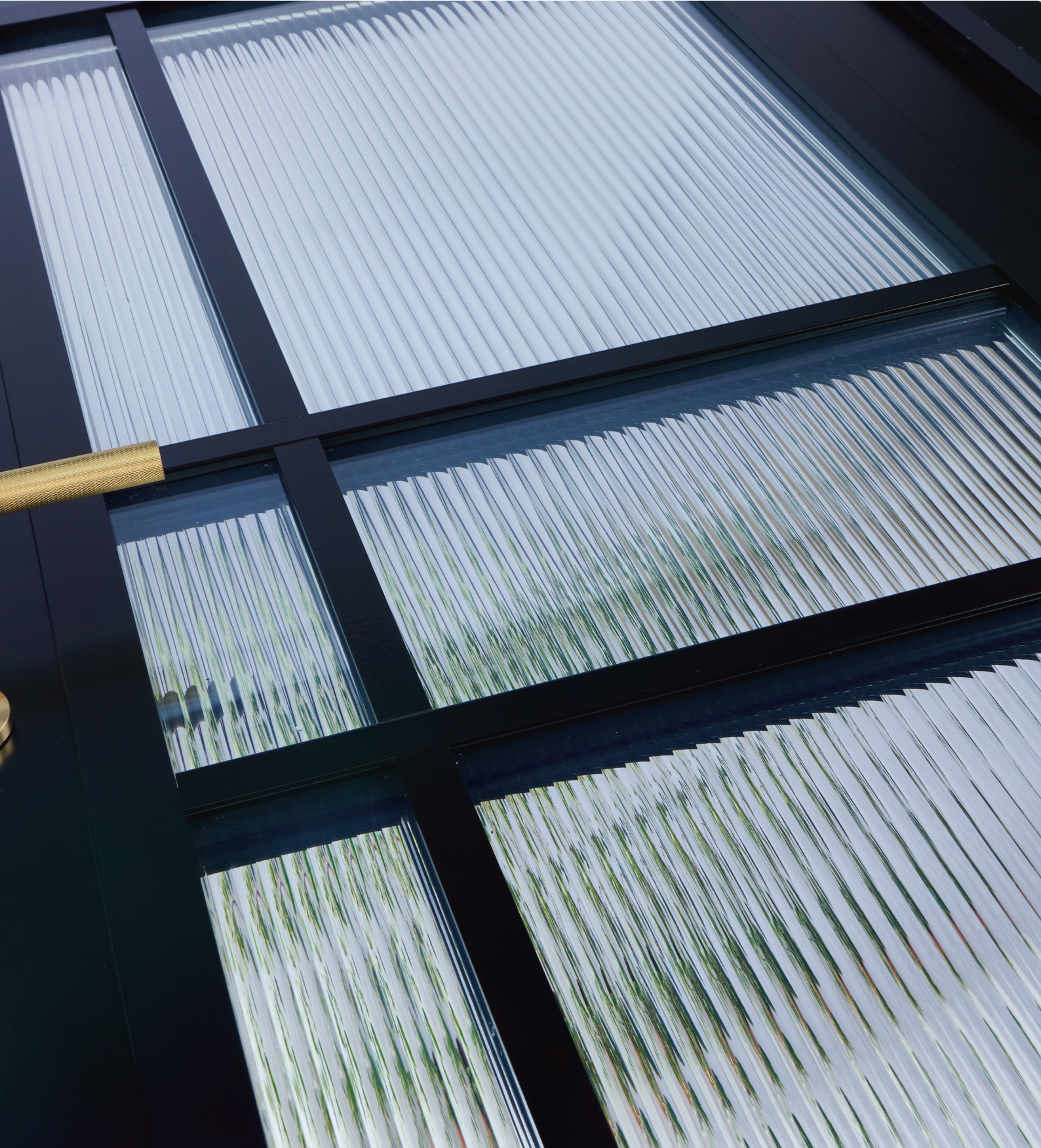

The Urban bar system has been designed as an easy to apply astragal bar solution for use with aluminium windows and doors. It utilizes a patented sprung steel clip fixing system to allow for ease of application, consistent line-throughs and long term performance. The system can be used as single bars or in multi-bar designs to create a heritage, steel window look.

INSULATED GLASS UNITS

To create the look of separate glass units a simulated divided light bar is used within the insulated glass unit. These can be created using specially designed single bars or with a 'duplex' system.

To ensure the optimal look on the completed installation, we recommend the following bar widths:

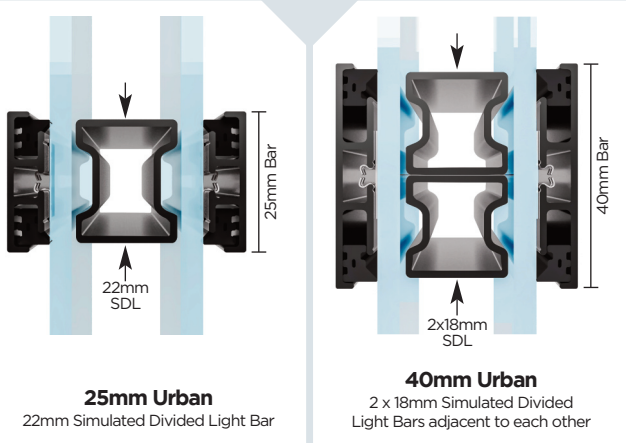

ADHESIVE TAPE

Clips are applied to the glass surface with a high performance foamed acrylic tape (Urbantape) which has been rigorously tested to ensure long term adhesion. The double sided tape is available in either Black or White.

Tape is to be applied across the full span of the clip and as it is a pressure sensitive adhesive it must be pressed down firmly so that the adhesive can 'wet-out'

Urban clips are available pre-taped.

CLIP LOCATIONS - SINGLE BAR

For single bar applications use only the single clips and they need to be located close to the edges of the glass unit and if the expanse is over 600mm, a further clip should be added centrally.

URBAN CLIP SYSTEM

The patented spring steel clips ensure that the bars are located accurately, and they prevent the risk of bars 'popping-off' which is common with adhesive tape applied bars. The clips are designed to allow for movement within the system.

The Urban Bar system uses 2 types of clips:

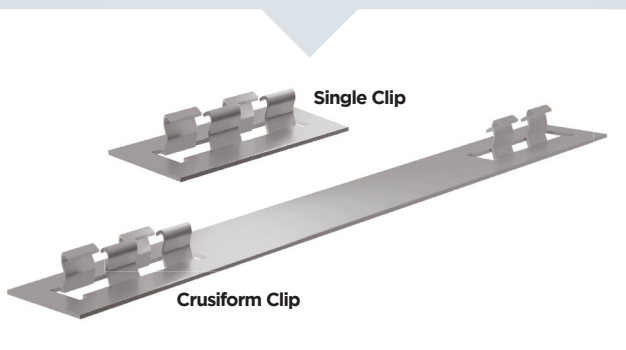

CLIP LOCATIONS - MULTI-BAR

For multi-bar designs with cross-overs, using the Cruciform Clip is recommended. The double ended Cruciform Clip goes under the continuous bar and ensures that the bars joining it are in line. Single clips should also be applied as close to any joints as possible.

For multi-bar applications, it is recommended that the horizontal bars are continuous, and the vertical bars are split.



APPLYING THE CLIPS

As most doors will need toe and heeling, the simulated divided bars should not be used as a location reference when applying clips. To ensure horizontal lines are accurate, the use of a laser level is recommended and clips should be placed along the laser line.

Ensure the glass is completely clean and grease free before applying clips. Alcohol wipes or an alcohol-based cleaner such as RegaClean No1, are recommended.

It is important that the clips are applied straight and following the laser line or the bar may not engage completely with the clips, particularly when multiple clips have been used.

CUTTING BAR

Firstly, cut the bars so they are slightly oversize. This makes them more handleable. Next insert the gasket into the channels.

To ensure a clean cut on the aluminium and to reduce the risk of rough ends or damage to the coating, a fine-tooth cutting blade designed for should be used. E.g. D-09628 blade for Makita saws.

Due to the possibility of expansion/contraction in the window or door system, particularly on darker colours, it is recommended that bars are cut 2-3mm short of the frames to allow for movement.

It is recommended that bars are bevel cut at the frame end so the bar can cover the gasket. On most gasket systems a 20 degree cut will suffice.

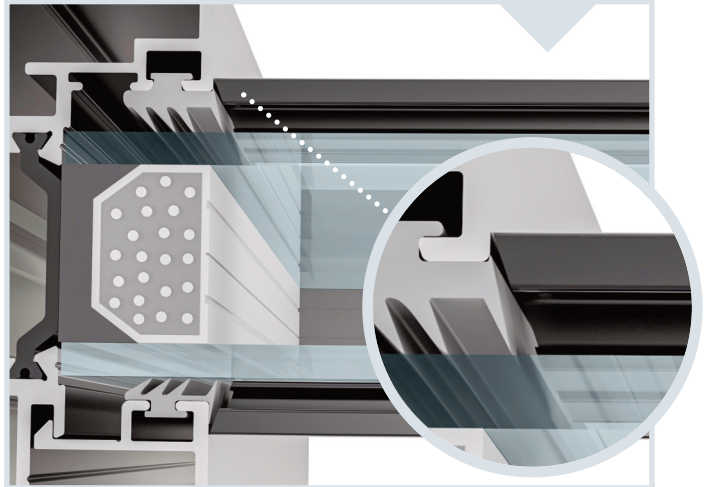

For cross over joints a 4 degree cut will reduce the chance of the bar end showing.

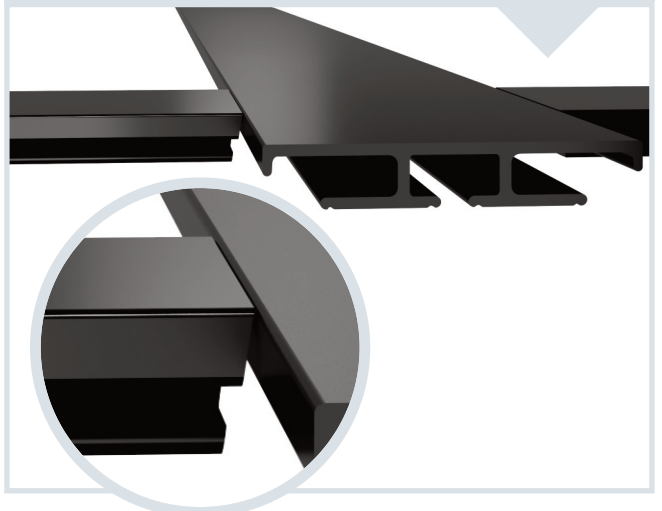

APPLYING THE BAR

Before applying the bar, ensure that none of the clips are damaged or folded in. If clips need opening this can be done easily with a flat head screwdriver.

Line the bars up with the clips and apply with a rolling motion to ensure the clips grip into the channel.

For multi-bar designs the continuous bars should always be applied first before the bevel cut pieces.



RegaLead[®]

Head Office (UK): RegaLead Ltd

Columbus House | Altrincham Road | Sharston | Manchester | M22 9AF | United Kingdom
Telephone +44 (0)161 946 1164 | Fax +44 (0)161 946 1033 | Email sales@regalead.co.uk

www.regalead.com