

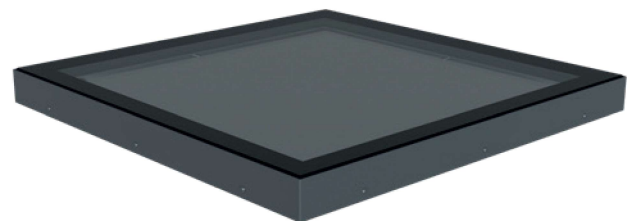

These installation instructions should be used for em.glaze Flat Glass Premium and Economy rooflights.

Contents

- 2 Tools Required & Installation Pack
- 2 Handling & Storage
- 2 Maintenance
- 3 Constructing & Waterproofing a Timber Upstand Kerb
- 3 Installing & Waterproofing a Proprietary Kerb
- 4 Assembling & Installing Fixed Unit onto Waterproofed Builder's Upstand
- 5 Assembling & Installing Fixed Unit onto PVC em.curb
- 5 Factory Installed PVC Opening Frame
- 6 Assembling & Installing Electric Opening Unit
- 7 Installing a Timber Sloping Upstand
- 8 Timber Sloping Upstand Sizes
- 9 Wiring & Commissioning Electric Opening Unit
- 10 Glass Thermal Stress Fracture

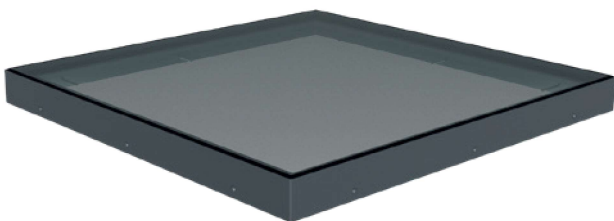

Product may vary

Tools Required

- Torque Adjustable Drill
- No.25 TX Torx Drive Bit
- Knife
- 3mm Drill Bit

Installation Pack

- Compriband Tape
- Fixing Screws

Please read this installation guide carefully before beginning your installation.

Contact your supplier if you are unsure about anything involved.

Handling & Storage

While all em.glaze flat glass rooflights and associated products are suitably packaged to avoid damage, you should take care when handling them. Always ensure you there's an appropriate number of people available to move larger items.

All rooflights, kerbs and accessories must be stored on a flat, dry surface under cover if they aren't going to be installed immediately. Please also ensure that heavy items are not stored on top of the units.

em.glaze flat glass rooflights should not be stored on edge at any time. This could cause detrimental damage to the silicone seal and create latent stresses within the glass.

em.glaze flat glass components should not at any time be left in direct sunlight until installation is complete. Heavy items should not be placed on top of them as this can lead to damage or distortion.

The HSE publication Safety in Roofwork HSG33 gives good advice on the necessary precautions, safe working practices and procedures that need to be adopted when working on roofs.

Maintenance

While em.glaze flat glass Premium rooflights are deemed non-fragile, all rooflights surfaces and should not be walked upon under any circumstances, unless the unit has been designed as a walk-on rooflight. A warranty condition is that after installation a competent person should check fixings, ventilation operation and sealing tape where applicable once a year and record results in maintenance records. Avoid all contact with: silicone, wood preservative, adhesives and sealing tapes.

Remove tar stains with turpentine and rinse thoroughly with water. Clean with mild soapy water (no abrasives) and always rinse with plenty of fresh water. In normal weather and site conditions, regular cleaning is recommended to maintain their present condition. Apart from cleaning and annual check no other regular maintenance should be necessary.

NB: Installation must comply with all applicable local building regulations.

Constructing & Waterproofing a Timber Upstand Kerb

Constructing:

Construct the upstand using relevant timber and insulation materials to achieve U value, slope angle and strength required. The top of the Kerb should be a minimum 50mm wide and maximum 120mm wide (including waterproofing membrane) and lowest point of Kerb 150mm above the finished roof level.

Upstand must be flat-topped (we recommend a 5° slope angle for water run-off. See Fig. 1). Apply the waterproofing (in accordance with Manufacturers Recommendations) up and right across top of upstand to give a flat even surface.

Construct the upstand according to the external size required. Note that the thickness of Kerb material will affect the daylight size.

- A Overall upstand size including waterproof membrane (external 1120 x 1120mm)
- B Internal upstand size dependant on width of Kerb
- C Minimum height: 150mm
- D Waterproofing membrane
- E Builders Kerb

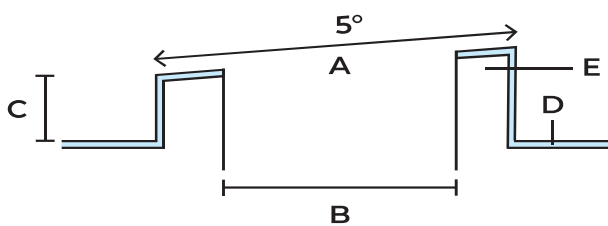

Fig. 1

Waterproofing:

Follow the waterproofing membranes manufacturer's recommendations for applying to timber ensuring the membrane is applied up side of Kerb and across top to inside edge of Kerb

Note: for asphalt or applications in excess of 13mm thick, we recommend contacting the Whitesales technical team to ensure rooflight can still be securely fixed on Kerb.

Installing & Waterproofing a Proprietary Kerb

Installing:

We recommend installing all PVC Kerbs on a 5° slope. If this isn't achieved via the roof slope, then you will need to add timber furring pieces under the base of the Kerb.

Drill and securely fix the Kerb to the roof aperture through the bottom flange, 100mm from each corner and at maximum 300mm centred.

Use very large-headed fixings (not supplied), with type and size dictated by site conditions. Upstand Kerbs should be fixed to a structural component (i.e. not fixed through insulation).

The 150mm-high Kerb should not be fitted below roof insulation. The 300mm high Kerb can be used with roof insulation up to 150mm thick if unvented, or up to 60mm thick if vented. If fitted with insulation in excess of these recommendations, a timber ground cut to 75mm wide x the required thickness should be provided around the roof aperture.

Waterproofing:

Apply the waterproofing (in accordance with the manufacturer's recommendations) up to the underside of the top flange (see Fig. 2). On vented 300mm-high Kerbs the waterproofing must be neatly dressed around the ventilators and up to the underside of the top flange.

Bitumen felt and torch-on systems: The em.curb should be primed and standard application techniques used. When using torch-on, the torch should be directed at the waterproofing and not directly at the em.curb (see Fig. 3).



Fig. 2

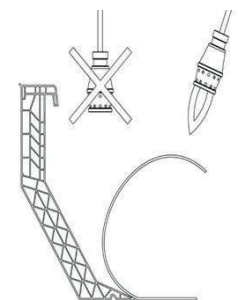

Fig. 3

Single ply systems: These may be solvent or heat-welded and mechanically fixed to the em.curb, depending on the type of membrane. Refer to the supplier for further information.

Asphalt: The em.curb should be primed and expanded metal lathe (EML) metal should be affixed using staples with a maximum length of 10mm. The first coat of asphalt should be applied cooler than usual – approximately 180°. This layer should be as thin as is practically possible. Because of the upstand's insulating properties, the heat cannot dissipate quickly and it is vital that you leave the first coat to cool completely before applying successive coats. These subsequent coats can be at normal temperature and thickness.

Assembling & Installing a Fixed, Non-Opening em.glaze Flat Glass Rooflight onto Waterproofed Builder's Upstand

1. Double check the external Kerb dimensions to ensure the upstand has been constructed to the correct sizing specification.

Note: Care should be taken to avoid damaging or scratching components.

2. Check size of rooflight and compare with the size of the external Kerb to make sure the rooflight will fit down over the Kerb (see sketch below).

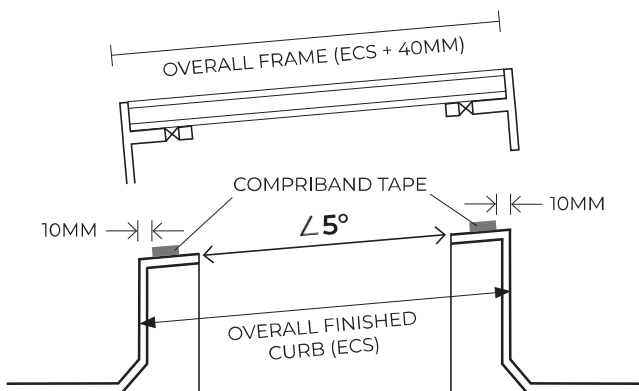
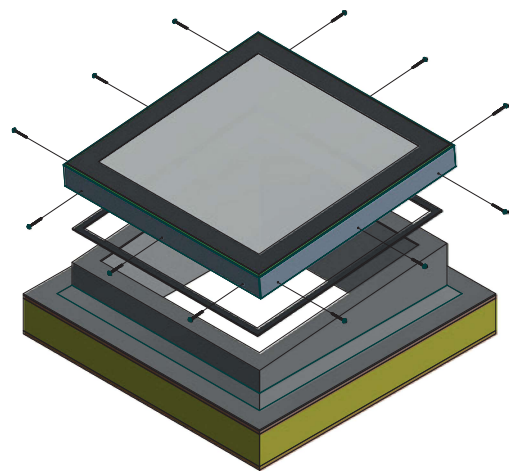

Fig. 4

3. Check that the Kerb is flat and in one continuous plane (maximum 5mm variation from extremities will be accommodated by compriband tape). We advise a minimum of 5° slope on the Kerb to minimize water pooling and potential staining

or aesthetic issues. Whilst the product can be installed flat without detriment to the warranties, the manufacturer cannot be held responsible for any excessive pooling of water to the surface of the rooflight post installation, if installed without an adequate fall.

4. Position and apply compriband tape to the top of the Kerb, so that it provides continuous seal with tight butt joints wherever tape meets or joins. See Fig. 4.
5. Position the rooflight onto the top of the Kerb ensuring the compriband tape is in continuous contact with the em.glaze unit around the full perimeter of the Kerb ensure that the unit is positioned centrally on Kerb with equal gap (minimum 10mm) between outside of Kerb and internal face of unit drip flange.
6. Using the fixing screws supplied, fix the frame to the Kerb horizontally through the fixing holes pre-drilled in the lower part of the perimeter frame. Depending on substrate pre-drill with 3mm drill bit if required to prevent splitting. Take care not to overtighten to avoid stripping fixing or distorting or damaging em.glaze frame.
7. **Please note:** Once the rooflight has been installed, all the protective film should be removed on the day of installation. The protective film, which has no UV protection, will become brittle and difficult to remove over time and may damage the paint if left for a prolonged period.



Assembling & Installing a Fixed, Non-Opening em.glaze Flat Glass Rooflight onto a PVC em.curb

1. Double check the external Kerb dimensions to ensure the upstand has been constructed to the correct sizing specification.

Note: Care should be taken to avoid damaging or scratching components.

2. Check size of rooflight and compare with the size of the external Kerb to make sure the rooflight will fit down over the Kerb.

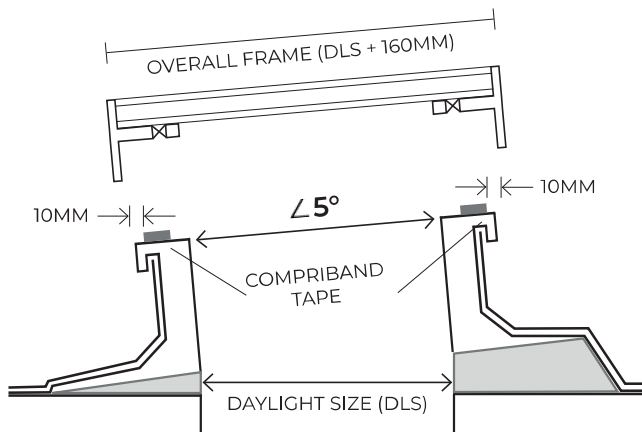
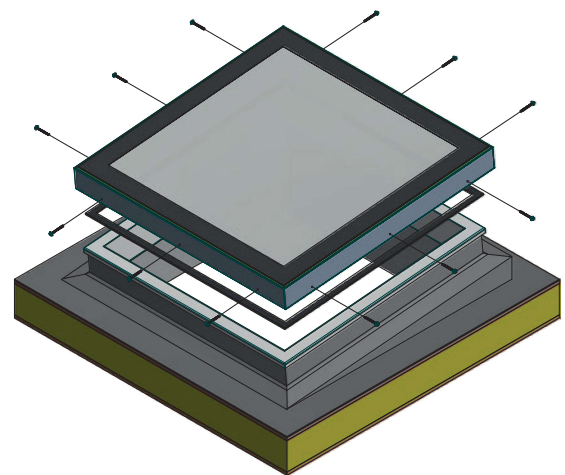

Fig. 5

3. Check that the em.curb is installed correctly and in one continuous plane. We advise a minimum of 5° slope on the Kerb to minimize water pooling and potential staining or aesthetic issues. Whilst the product can be installed without detriment to the warranties, the manufacturer cannot be held responsible for any excessive pooling of water to the surface of the rooflight post installation, if installed without an adequate fall.
4. Position and apply compriband tape to the top of the em.curb, so that it provides continuous seal with tight butt joints wherever tape meets or joins. See Fig. 6.
5. Position the rooflight onto the top of the Kerb ensuring the compriband tape is in contact with the metal frame around the full perimeter of the Kerb. Ensure that the unit is positioned centrally on Kerb with equal gap (minimum 10mm) between outside of em.curb and internal face of em.glaze unit drip flange.
6. Using the fixing screws supplied, fix the frame to the Kerb horizontally through the fixing holes

pre-drilled in the lower part of the perimeter frame. Take care not to overtighten to avoid stripping PVC or distorting or damaging em.glaze frame.

7. **Please note:** Once the rooflight has been installed, all the protective film should be removed on the day of installation. The protective film, which has no UV protection, will become brittle and difficult to remove over time and may damage the paint if left for a prolonged period.
8. Clean and snag any details.



Factory Installed PVC Opening Frames

For manually opening ventilation, clip the opening spindle into the mounting brackets. Adjust as necessary using the inner spindle to give the correct closed position (see instructions on spindle packaging). Ensure spindle is aligned vertically before fixing unit.

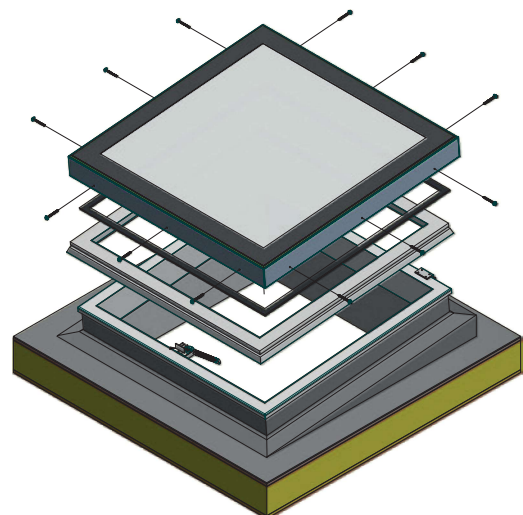

Assembling & Installing an Electric Opening em.glaze Flat Glass Rooflight

Note: These instructions are to be used in conjunction with installation guide of fixed units as detailed below.

- 1-3 Follow points 1-3 from relevant Kerb (builder's upstand or PVC em.curb from the fixed units above).
4. It is recommended the unit is installed with the hinges on the high side. The unit should never be installed with the hinges on the sloped elevation as this will cause excessive forces on the motor chain and hinges and could lead to premature failure or non operation of the unit. Identify how unit will sit on Kerb. Check unit to be installed for cable exit position on underside of unit (hinge side). Measure position of cable exit from corner and mark corresponding position on the Kerb (remember to allow for the overhang of the unit past the Kerb). Drill a minimum 12mm hole for the cable route through the Kerb.

5. Position and apply compriband tape to the top of the em.curb, so that it provides continuous seal with tight butt joints wherever tape meets or joins. See Fig. 7.
6. Position rooflight adjacent to Kerb and feed motor cable through Kerb.
7. Position the rooflight onto the top of the Kerb ensuring the compriband tape is in contact with the metal frame around the full perimeter of the Kerb ensure that the unit is positioned centrally on Kerb with equal gap (minimum 10mm) between outside of em.curb and internal face of em.glaze unit drip flange. Take care not to trap or pinch cable.
8. Using the fixing screws supplied, fix the frame to the Kerb horizontally through the fixing holes pre-drilled in the lower part of the perimeter frame.
9. **Please note:** Once the rooflight has been installed, all the protective film should be removed on the day of installation. The protective film, which has no UV protection, will become brittle and difficult to remove over time and may damage the paint if left for a prolonged period.
10. Clean and snag any details.

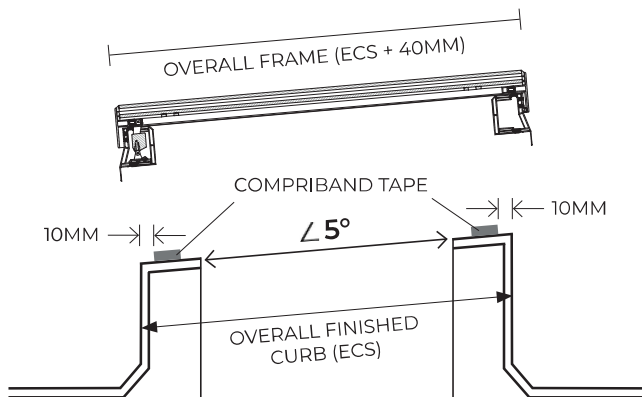
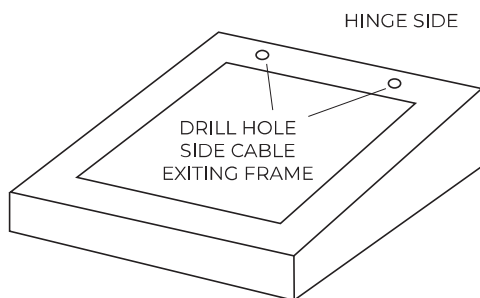
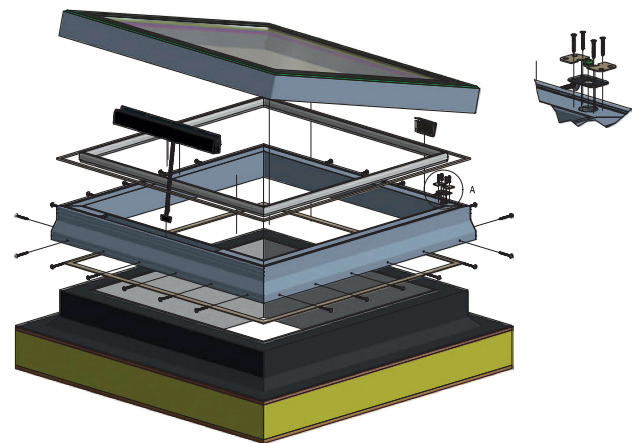

Fig. 6



CHECK WHICH SIDE CABLE EXITING UNDERSIDE OF FRAME AND MEASURE IN FROM CORNER.

Fig. 7



Timber Sloping Upstand Instructions

Before installing your Whitesales Timber Sloping Upstand [TSU]: Please make sure you comply with all H&S regulations, and are working in a safe environment, with the correct safety measures' and equipment in place.

Now you are in possession of your product, please remove from packaging, near the roof opening, for ease of installation. Note: larger iterations of the Timber Sloping Upstand have a substantial weight (see accompanying reference table). To comply with Health & Safety regulations, please consider the use of additional lifting equipment where necessary. Then...

1. Place your Timber Sloping Upstand into position over the roof opening, double checking the internal upstand dimensions align correctly with the specification.
2. Check that the upstand is square and sloped to the correct orientation with respect to the

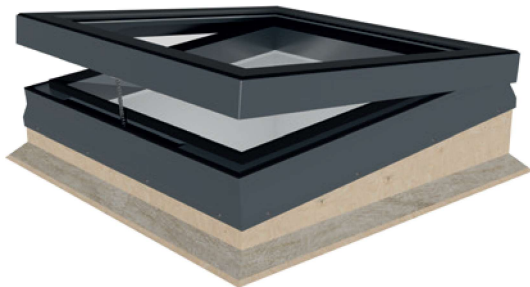

TSU FITTED WITH EM.GLAZE & CONCEALED ACTUATOR



fall of the roof to minimize water pooling and potential staining or aesthetic issues. The manufacturer cannot be held responsible for any excessive pooling of water to the surface of the rooflight post installation, if installed without an adequate fall.

3. Pre-drill perpendicular into the tilt fillet of the Timber Sloping Upstand, connecting it to the roof, with a 6mm drill bit at minimum of 300mm centres. Affix into place using a minimum of 5mm dia x 70 mm woodscrews through the predrilled holes. Work around the perimeter of the upstand fillet, ensuring the Timber Sloping Upstand is securely in place. Ensure all fixing screws are flush with the surface of the tilt fillet.
4. If the rooflight is of size which requires straps (sizes in excess of 2100mm x 2100mm), remove the pre-affixed plasterboard on the internal face. The metal straps provided will need to be attached to the timber uprights, from the top rail to the primary Kerb. Two fixings to the top rail and four fixings into the primary Kerb. Fixings should be 3.75mm dia. X 40mm long square twist nails. Upon completion of the affixing of the metal straps, the plasterboard on the internal face must be re-affixed.

Timber Sloping Upstand Instructions

5. Appropriate waterproofing membrane can now be affixed into position from the roof surface, over the tilt fillet and up the external face of the Timber Sloping Upstand, and across the top of the upstand.
6. Position and apply compriband tape supplied with the em.glaze rooflight, to the underside of the em.glaze unit on the aluminium frame (not the glass), so that it provides continuous seal with tight butt joints wherever tape meets or joins.
7. Place the em.glaze rooflight to the top of the now weathered, Timber Sloping Upstand and use fixing screws to secure the em.glaze rooflight into place via the side faces.
8. Please note: Once the rooflight has been installed, all the protective film should be removed on the day of installation. The protective film, which has no UV protection, will become brittle and difficult to remove over time and may damage the paint if left for a prolonged period.
9. Clean and snag any details. Dispose of any excess materials, packaging and other waste in line with local environmental regulations.

| Size Code | Approx. Weight [KG] (unit only) |
|-----------|---------------------------------|
| R5 | 28.8 |
| R6 | 34.0 |
| R6m | 55.6 |
| R7 | 32.7 |
| R16 | 40.9 |
| R17a | 48.9 |
| R19 | 58.8 |
| R22z | 77.3 |
| R30a | 91.8 |
| S2 | 19.8 |
| S4 | 23.5 |
| S5 | 27.5 |
| S7 | 31.6 |
| S8 | 35.6 |
| S9 | 39.6 |
| S11 | 47.9 |
| S13 | 57.3 |
| S17 | 86.3 |

Wiring & Commissioning an Electric Opening em.glaze Flat Glass Rooflight

Note: Electrical wiring and commissioning should only be carried out by a qualified and competent person.

Every em.glaze electric unit is bench tested during production and leaves the factory fully operational.

Due to the size and weight differences between units there are combination of single and multiple motor combinations and different capacity (Nm) motors that are used.

Every unit should have a specific motor guide attached to the motor cable – if you require electronic versions or are missing this guide please contact Whitesales customer services team.

PLEASE PASS ONTO BUILDING OWNER/OCCUPIER.

Glass Thermal Fracture

Your em.glaze rooflight is generally supplied with the internal pane as laminated glass to give maximum safety and security to personnel internally and externally.

Annealed laminated glass could be subject to thermal fracture and care should be taken to avoid uneven heat build-up under the glass.

Any installation of blinds, film or alterations to roof light-well, or other heat sources must consider the above and be installed/used in such a way to prevent risk of thermal fracture.

Further guidance can be obtained by contacting our Technical Team using the details below.

Contact Details

Whitesales Ltd, Europa House, Alfold Road,
Cranleigh, Surrey, GU6 8NQ

Tel: 01483 917580

Email: sales@whitesales.co.uk

Web: whitesales.co.uk



whitesales
experience.brighter

experience.brighter

Delivering on our promises, that is our focus – and it is what makes us the no.1 choice for professionals.

Nationwide coverage and next-day delivery:

Our delivery depot holds large volumes of stock, allowing us to supply orders at short notice – including next-day delivery if ordered by 2pm, in most cases.



Europa House, Alfold Road,
Cranleigh, GU6 8NQ
Tel: 01483 917580 | Fax: 01483 271771
sales@whitesales.co.uk | whitesales.co.uk

Opening Times: 07:30–16:30

